

FCC Test Report

Report No.: FV190401D10A

Test Model: EMBC-2000

Series Model: EMBC-2XXXX-XXXX series ("X" can be 0-9, A-Z or blank for marketing purpose)

Received Date: Apr. 1, 2019

Test Date: Apr. 10 to 11, 2019

Issued Date: May 28, 2019

Applicant: Vecow Co., Ltd.

Address: 3F., No.10, Jiankang Rd., Zhonghe Dist., New Taipei City 23586, Taiwan

Issued By: Bureau Veritas Consumer Products Services (H.K.) Ltd., Taoyuan Branch

Lab Address: No. 47-2, 14th Ling, Chia Pau Vil., Lin Kou Dist., New Taipei City, Taiwan (R.O.C.)

**FCC Registration/
Designation Number:** 418586 / TW1078



This report is for your exclusive use. Any copying or replication of this report to or for any other person or entity, or use of our name or trademark, is permitted only with our prior written permission. This report sets forth our findings solely with respect to the test samples identified herein. The results set forth in this report are not indicative or representative of the quality or characteristics of the lot from which a test sample was taken or any similar or identical product unless specifically and expressly noted. Our report includes all of the tests requested by you and the results thereof based upon the information that you provided to us. You have 60 days from date of issuance of this report to notify us of any material error or omission caused by our negligence, provided, however, that such notice shall be in writing and shall specifically address the issue you wish to raise. A failure to raise such issue within the prescribed time shall constitute your unqualified acceptance of the completeness of this report, the tests conducted and the correctness of the report contents. Unless specific mention, the uncertainty of measurement has been explicitly taken into account to declare the compliance or non-compliance to the specification. The report must not be used by the client to claim product certification, approval, or endorsement by A2LA or any agency of the U.S. government. The report must not be used by the client to claim product certification, approval, or endorsement by TAF or any government agencies.

Table of Contents

Release Control Record	3
1 Certificate of Conformity	4
2 Summary of Test Results	5
2.1 Measurement Uncertainty	5
2.2 Modification Record	5
3 General Information	6
3.1 Description of EUT	6
3.2 Features of EUT	6
3.3 Operating Modes of EUT and Determination of Worst Case Operating Mode	7
3.4 Test Program Used and Operation Descriptions.....	7
3.5 Primary Clock Frequencies of Internal Source	7
4 Configuration and Connections with EUT	8
4.1 Connection Diagram of EUT and Peripheral Devices.....	8
4.2 Configuration of Peripheral Devices and Cable Connections.....	9
5 Conducted Emissions at Mains Ports	10
5.1 Limits	10
5.2 Test Instruments	10
5.3 Test Arrangement	11
5.4 Test Results.....	12
6 Radiated Emissions up to 1 GHz	14
6.1 Limits	14
6.2 Test Instruments	14
6.3 Test Arrangement	15
6.4 Test Results.....	16
7 Radiated Emissions above 1 GHz	18
7.1 Limits	18
7.2 Test Instruments	19
7.3 Test Arrangement	20
7.4 Test Results.....	21
8 Pictures of Test Arrangements	23
8.1 Conducted Emissions at Mains Ports	23
8.2 Radiated Emissions up to 1 GHz	24
8.3 Radiated Emissions above 1 GHz	25
Appendix – Information of the Testing Laboratories	26

Release Control Record

Issue No.	Description	Date Issued
FV190401D10A	Original release.	May 28, 2019

1 Certificate of Conformity

Product: Motherboard

Brand: Vecow

Test Model: EMBC-2000

Series Model: EMBC-2XXXX-XXXX series ("X" can be 0-9, A-Z or blank for marketing purpose)

Sample Status: Engineering sample

Applicant: Vecow Co., Ltd.

Test Date: Apr. 10 to 11, 2019

Standards: 47 CFR FCC Part 15, Subpart B, Class A
ICES-003: 2016 Issue 6, updated Apr. 2019 Class A
ANSI C63.4:2014

The above equipment has been tested by **Bureau Veritas Consumer Products Services (H.K.) Ltd., Taoyuan Branch**, and found compliance with the requirement of the above standards. The test record, data evaluation & Equipment Under Test (EUT) configurations represented herein are true and accurate accounts of the measurements of the sample's EMC characteristics under the conditions specified in this report.

Prepared by :



, Date: May 28, 2019

Albee Chu / Specialist

Approved by :



, Date: May 28, 2019

Jim Hsiang / Associate Technical Manager

2 Summary of Test Results

47 CFR FCC Part 15, Subpart B / ICES-003: 2016 Issue 6, updated Apr. 2019 Class A

ANSI C63.4:2014

FCC Clause	ICES-003 Clause	Test Item	Result/Remarks	Verdict
15.107	6.1	AC Power Line Conducted Emissions	Minimum passing Class A margin is -18.85 dB at 13.99300 MHz	Pass
15.109	6.2.1	Radiated Emissions up to 1 GHz	Minimum passing Class A margin is -2.06 dB at 224.34 & 295.64 MHz	Pass
	6.2.2	Radiated Emissions above 1 GHz	Minimum passing Class A margin is -18.91 dB at 1996.65 MHz	Pass

Note:

1. There is no deviation to the applied test methods and requirements covered by the scope of this report.
2. Determining compliance based on the results of the compliance measurement, not taking into account measurement instrumentation uncertainty.

2.1 Measurement Uncertainty

Where relevant, the following measurement uncertainty levels have been estimated for tests performed on the EUT:

Measurement	Frequency	Expanded Uncertainty (k=2) (±)
Conducted Emissions at mains ports	150kHz ~ 30MHz	2.79 dB
Radiated Emissions up to 1 GHz	30MHz ~ 1GHz	3.91 dB
Radiated Emissions above 1 GHz	1GHz ~ 6GHz	5.12 dB
	Above 6GHz	5.09 dB

2.2 Modification Record

There were no modifications required for compliance.

3 General Information

3.1 Description of EUT

Product	Motherboard
Brand	Vecow
Test Model	EMBC-2000
Series Model	EMBC-2XXXX-XXXX series ("X" can be 0-9, A-Z or blank for marketing purpose)
Model Difference	Marketing Differentiation
Sample Status	Engineering sample
Operating Software	N/A
Power Supply Rating	DC from host equipment
Accessory Device	N/A
Data Cable Supplied	N/A

Note:

1. The EUT is a Motherboard with resolution up to 3480 x 2160 @ 30Hz (HDMI) and 1920 x 1440 @ 60Hz (VGA).
2. The EUT was installed into a PC (Brand: Vecow, Model: SPC-4020A), which was configured with the following key components

Processor	Intel Atom® x7-E3950 Processor (Apollo Lake-I)
BIOS	AMI
SIO	IT8786E
Memory	1 DDR3L 1866MHz SO-DIMM, up to 8GB
OS	Windows 10, Linux

3. The PC uses following adapter and it was provided for test by client:

Brand	MW
Model	GST280A12
Input Power	100-240Vac, 50/60Hz, 4.5A
Output Power	12V, 21A, 252W
Power Line	Non-shielded DC (1.0m) with two ferrite cores

3.2 Features of EUT

The tests reported herein were performed according to the method specified by Vecow Co., Ltd., for detailed feature description, please refer to the manufacturer's specifications or user's manual.

3.3 Operating Modes of EUT and Determination of Worst Case Operating Mode

1. The EUT consumes power from PC, which designed with AC power supply of rating 100-240Vac, 50/60Hz.
For radiated emission evaluation, 230Vac/50Hz & 110Vac/60Hz (EN 55032), 120Vac/60Hz (for FCC Part 15) had been covered during the pre-test. The worst data was found at **110Vac/60Hz** and recorded in the applied test report. Then the other test items were tested at 120Vac/60Hz.
2. Test modes are presented in the report as below.

Mode	Test Condition	Input Power (System)
Conducted emission test		
1	Full system, HDMI (3480 x 2160 @ 30Hz)+ VGA* (1920x 1200 @ 60Hz)	120Vac/ 60Hz
Radiated emission test		
1	Full system, HDMI (3480 x 2160 @ 30Hz)+ VGA* (1920x 1200 @ 60Hz)	110Vac/60Hz

Note: *The maximum resolution of the external display monitor is 1920x 1200 @ 60Hz.

3.4 Test Program Used and Operation Descriptions

- a. Installed the EUT into PC.
- b. Turned on the power of all equipment.
- c. PC ran a test program to enable all functions.
- d. PC read and wrote messages from/to SSD and ext. HDD.
- e. PC sent and received messages to/from Notebook PCs (kept in a remote area) via two LAN cables.
- f. PC sent "H" messages to ext. LCD Monitors. Then they displayed "H" patterns on their screens simultaneously.
- g. PC sent 1kHz audio signal to earphone.
- h. PC sent messages to modem.
- i. PC sent messages to printer and printer printed them out.
- j. Steps d-i were repeated.

3.5 Primary Clock Frequencies of Internal Source

The highest frequency generated or used within the EUT or on which the EUT operates or tunes is 1600 MHz, provided by Vecow Co., Ltd., for detailed internal source, please refer to the manufacturer's specifications.

4 Configuration and Connections with EUT

4.1 Connection Diagram of EUT and Peripheral Devices

TEST CONFIGURATION

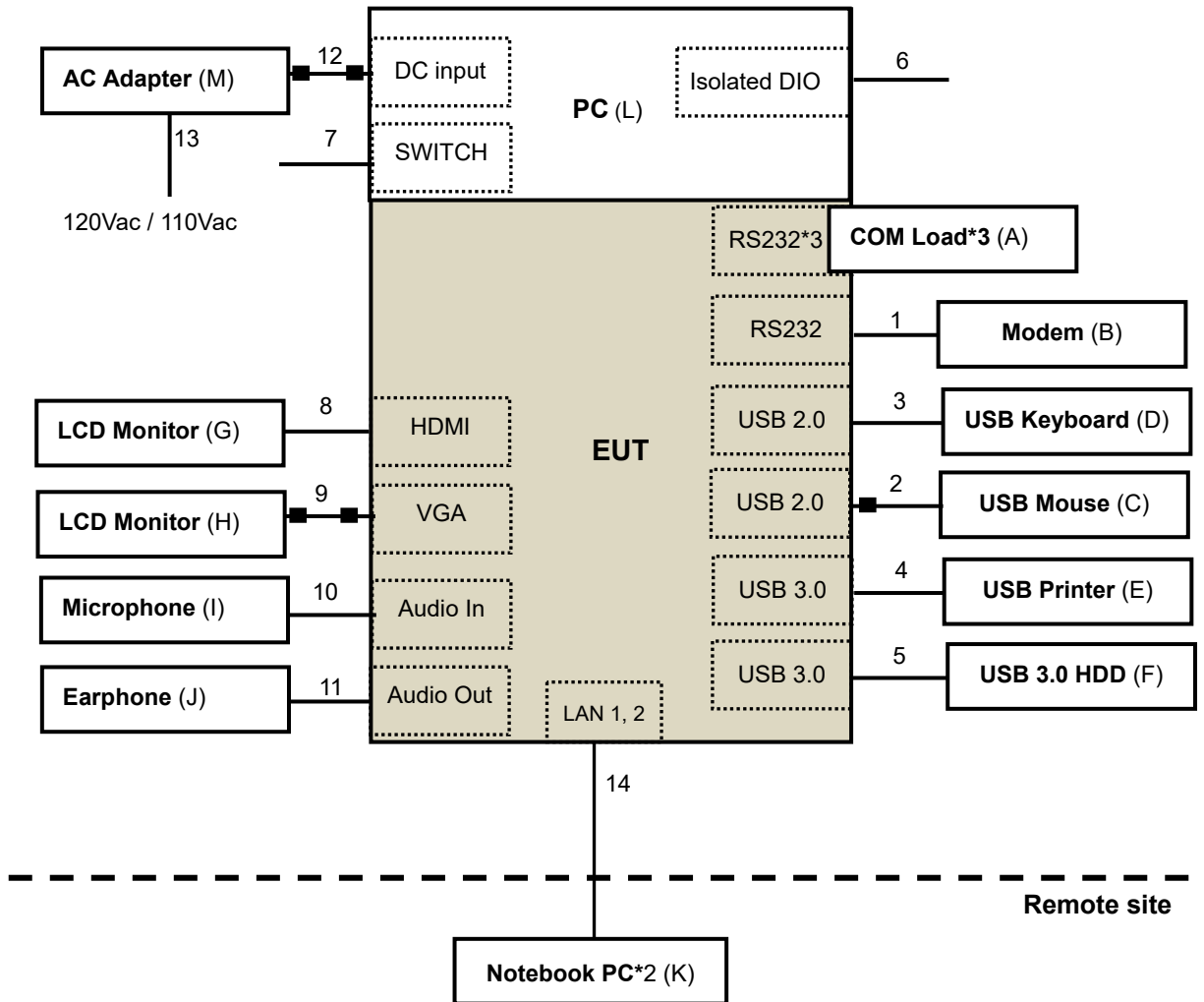

4.2 Configuration of Peripheral Devices and Cable Connections

ID	Product	Brand	Model No.	Serial No.	FCC ID	Remarks
A.	COM Load*3	N/A	N/A	N/A	N/A	Provided by Lab
B.	MODEM	ACEEX	1414	980020531	IFAXDM1414	Provided by Lab
C.	USB Mouse	Microsoft	1113	9170515772204	FCC DoC Approved	Provided by Lab
D.	USB KEYBOARD	Dell	KB216t	CN-0W33XP-LO300-7CL-1907	FCC DoC Approved	Provided by Lab
E.	Printer	HP	Officejet pro 251dw	N/A	B94SDGOB1191	Provided by Lab
F.	USB 3.0 Hard Disk	WD	WDBUZG0010BBK-PESN	WXF1E84H2ASN	FCC DoC Approved	Provided by Lab
G.	LCD Monitor	ASUS	MG28UQ	H8LMTF147971	FCC DoC Approved	Provided by Lab
H.	LCD Monitor	DELL	U2410	CN082WXD728720 CC10NL	FCC DoC Approved	Provided by Lab
I.	MICROPHONE	Labtec	mic-333	N/A	N/A	Provided by Lab
J.	EARPHONE	PHILIPS	SBC HL145	N/A	N/A	Provided by Lab
K.	Notebook PC	DELL	P41G	FT4W952	FCC DoC Approved	Provided by Lab
	Notebook PC	ASUS	PU401L	ECNXBC012528528	FCC DoC Approved	Provided by Lab
L.	PC	Vecow	SPC-4020A	N/A	N/A	Supplied by client
M.	AC Adapter	MW	GST280A12	N/A	N/A	Supplied by client

Note:

1. All power cords of the above support units are non-shielded (1.8m).
2. Item K acted as communication partners to transfer data.

ID	Descriptions	Qty.	Length (m)	Shielding (Yes/No)	Cores (Qty.)	Remarks
1.	RS232 cable	1	1.2	Y	0	Provided by Lab
2.	USB cable	1	1.8	Y	1	Provided by Lab
3.	USB cable	1	1.8	Y	0	Provided by Lab
4.	USB cable	1	1.8	Y	0	Provided by Lab
5.	USB cable	1	0.5	Y	0	Provided by Lab
6.	Signal cable	1	0.3	N	0	Supplied by client
7.	Signal cable	1	0.7	N	0	Supplied by client
8.	HDMI cable	1	2.0	Y	0	Provided by Lab
9.	D-Sub cable	1	1.8	Y	2	Provided by Lab
10.	Audio cable	1	1.2	N	0	Provided by Lab
11.	Audio cable	1	2.2	N	0	Provided by Lab
12.	DC power	1	1.0	N	2	Supplied by client
13.	AC power cord	1	1.8	N	0	Provided by Lab
14.	LAN cable (Cat.5e)	2	10	N	0	Provided by Lab

Note: The core(s) is(are) originally attached to the cable(s).

5 Conducted Emissions at Mains Ports

5.1 Limits

Frequency (MHz)	Class A (dBUV)		Class B (dBUV)	
	Quasi-peak	Average	Quasi-peak	Average
0.15 - 0.5	79	66	66 - 56	56 - 46
0.50 - 5.0	73	60	56	46
5.0 - 30.0	73	60	60	50

Notes: 1. The lower limit shall apply at the transition frequencies.
2. The limit decreases linearly with the logarithm of the frequency in the range of 0.15 to 0.50 MHz.

5.2 Test Instruments

Description & Manufacturer	Model No.	Serial No.	Cal. Date	Cal. Due
ROHDE & SCHWARZ TEST RECEIVER	ESR3	102414	Jan. 17, 2019	Jan. 16, 2020
ROHDE & SCHWARZ Artificial Mains Network (for EUT)	ENV216	101197	May 23, 2018	May 22, 2019
LISN With Adapter (for EUT)	AD10	C10Ada-002	May 23, 2018	May 22, 2019
ROHDE & SCHWARZ Artificial Mains Network (for peripherals)	ESH3-Z5	100218	Nov. 30, 2018	Nov. 29, 2019
SCHWARZBECK Artificial Mains Network (For EUT)	NNLK8129	8129229	May 3, 2018	May 2, 2019
SCHWARZBECK Artificial Mains Network (For EUT)	NNLK 8121	8121-808	Mar. 15, 2019	Mar. 14, 2020
Software	Cond_V7.3.7.4	NA	NA	NA
RF cable (JYEBAO) With 10dB PAD	5D-FB	Cable-C10.01	Feb. 13, 2019	Feb. 12, 2020
SUHNER Terminator (For ROHDE & SCHWARZ LISN)	65BNC-5001	E1-011484	May 8, 2018	May 7, 2019
ROHDE & SCHWARZ Artificial Mains Network (For TV EUT)	ESH3-Z5	100220	Nov. 21, 2018	Nov. 20, 2019
LISN With Adapter (for TV EUT)	100220	NA	Nov. 21, 2018	Nov. 20, 2019

Note: 1. The calibration interval of the above test instruments is 12 months and the calibrations are traceable to NML/ROC and NIST/USA.
2. The test was performed in Shielded Room No. 10.
3. The VCCI Site Registration No. C-11852.
4. Tested Date: Apr. 11, 2019

5.3 Test Arrangement

- The EUT was placed 0.4 meters from the conducting wall of the shielded room with EUT being connected to the power mains through a line impedance stabilization network (LISN). Other support units were connected to the power mains through another LISN. The two LISNs provide 50 Ohm/ 50uH of coupling impedance for the measuring instrument.
- Both lines of the power mains connected to the EUT were checked for maximum conducted interference.
- The test results of conducted emissions at mains ports are recorded of six worst margins for quasi-peak (mandatory) [and average (if necessary)] values against the limits at frequencies of interest unless the margin is 20 dB or greater.

Note: The resolution bandwidth and video bandwidth of test receiver is 9kHz for quasi-peak detection (QP) and average detection (AV) at frequency 0.15MHz-30MHz.

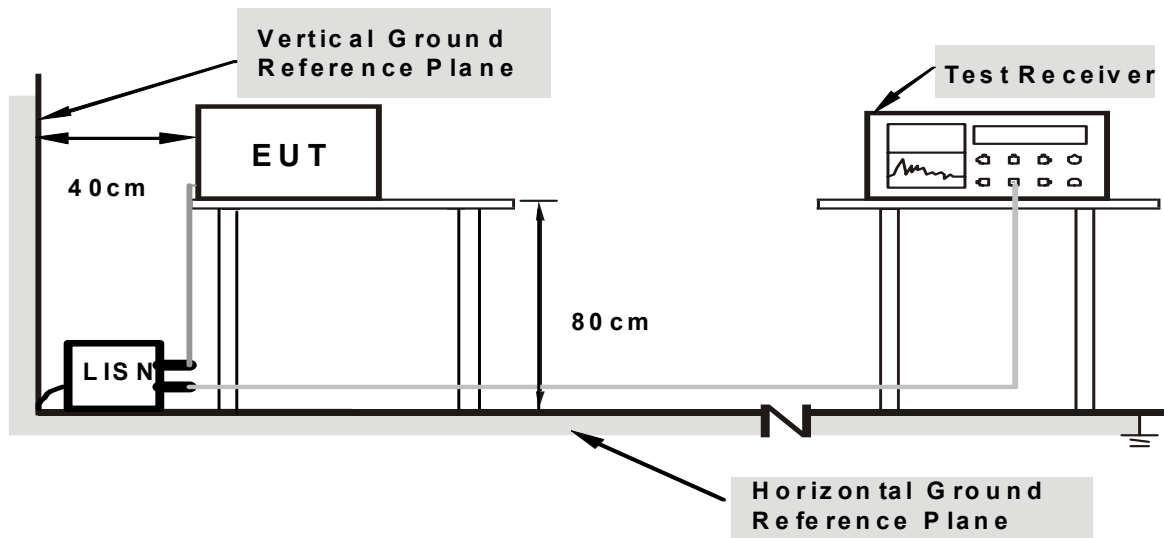

Note: Support units were connected to second LISN.

For the actual test configuration, please refer to the related item – Photographs of the Test Configuration.

5.4 Test Results

Frequency Range	150kHz ~ 30MHz	Detector Function & Resolution Bandwidth	Quasi-Peak (QP) / Average (AV), 9kHz
Input Power (System)	120Vac, 60Hz	Environmental Conditions	25°C, 69%RH
Tested by	Mick Chou		
Test Mode	Mode 1		

Phase Of Power : Line (L)										
No	Frequency (MHz)	Correction Factor (dB)	Reading Value (dBuV)		Emission Level (dBuV)		Limit (dBuV)		Margin (dB)	
			Q.P.	AV.	Q.P.	AV.	Q.P.	AV.	Q.P.	AV.
1	0.38069	9.70	32.91	25.66	42.61	35.36	79.00	66.00	-36.39	-30.64
2	0.42761	9.70	32.47	25.12	42.17	34.82	79.00	66.00	-36.83	-31.18
3	0.62030	9.72	31.63	26.89	41.35	36.61	73.00	60.00	-31.65	-23.39
4	0.66813	9.73	33.62	28.86	43.35	38.59	73.00	60.00	-29.65	-21.41
5	11.10742	9.96	32.80	27.03	42.76	36.99	73.00	60.00	-30.24	-23.01
6	14.97050	9.99	35.16	27.95	45.15	37.94	73.00	60.00	-27.85	-22.06

Remarks:

1. Q.P. and AV. are abbreviations of quasi-peak and average individually.
2. The emission levels of other frequencies were very low against the limit.
3. Margin value = Emission level – Limit value
4. Correction factor = Insertion loss + Cable loss
5. Emission Level = Correction Factor + Reading Value

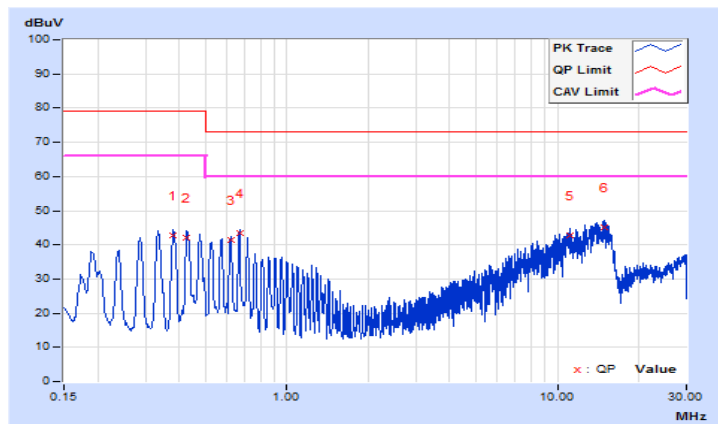

Frequency Range	150kHz ~ 30MHz	Detector Function & Resolution Bandwidth	Quasi-Peak (QP) / Average (AV), 9kHz
Input Power (System)	120Vac, 60Hz	Environmental Conditions	25°C, 69%RH
Tested by	Mick Chou		
Test Mode	Mode 1		

Phase Of Power : Neutral (N)										
No	Frequency (MHz)	Correction Factor (dB)	Reading Value (dBuV)		Emission Level (dBuV)		Limit (dBuV)		Margin (dB)	
			Q.P.	AV.	Q.P.	AV.	Q.P.	AV.	Q.P.	AV.
1	0.38069	9.71	32.83	25.54	42.54	35.25	79.00	66.00	-36.46	-30.75
2	0.42761	9.71	32.41	24.87	42.12	34.58	79.00	66.00	-36.88	-31.42
3	0.47788	9.72	31.40	24.48	41.12	34.20	79.00	66.00	-37.88	-31.80
4	0.66813	9.74	33.64	28.82	43.38	38.56	73.00	60.00	-29.62	-21.44
5	7.77219	9.92	29.32	24.49	39.24	34.41	73.00	60.00	-33.76	-25.59
6	13.99300	10.02	34.20	31.13	44.22	41.15	73.00	60.00	-28.78	-18.85

Remarks:

1. Q.P. and AV. are abbreviations of quasi-peak and average individually.
2. The emission levels of other frequencies were very low against the limit.
3. Margin value = Emission level – Limit value
4. Correction factor = Insertion loss + Cable loss
5. Emission Level = Correction Factor + Reading Value

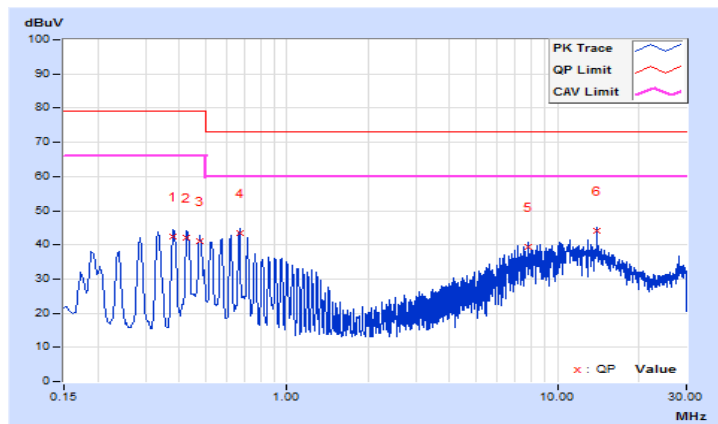

6 Radiated Emissions up to 1 GHz

6.1 Limits

Emissions radiated outside of the specified bands, shall be according to the general radiated limits as following:

Radiated Emissions Limits at 10 meters (dB μ V/m)				
Frequencies (MHz)	FCC 15B / ICES-003, Class A	FCC 15B / ICES-003, Class B	CISPR 22, Class A	CISPR 22, Class B
30-88	39	29.5	40	30
88-216	43.5	33.1		
216-230	46.4	35.6		
230-960			47	37
960-1000	49.5	43.5		

Radiated Emissions Limits at 3 meters (dB μ V/m)				
Frequencies (MHz)	FCC 15B / ICES-003, Class A	FCC 15B / ICES-003, Class B	CISPR 22, Class A	CISPR 22, Class B
30-88	49.5	40	50.5	40.5
88-216	54	43.5		
216-230	56.9	46		
230-960			57.5	47.5
960-1000	60	54		

- Notes:
1. The lower limit shall apply at the transition frequencies.
 2. Emission level (dB μ V/m) = 20 log Emission level (uV/m).
 3. QP detector shall be applied if not specified.

6.2 Test Instruments

Description & Manufacturer	Model No.	Serial No.	Cal. Date	Cal. Due
ROHDE & SCHWARZ TEST RECEIVER	ESCI	100744	May 7, 2018	May 6, 2019
Schaffner BILOG Antenna	CBL6111D	22270	Nov. 21, 2018	Nov. 20, 2019
Sonoma Preamplifier	310N	352921	Feb. 19, 2019	Feb. 18, 2020
CT Turn Table	TT100	CT-080	NA	NA
CT Tower	AT100	CT-080	NA	NA
Software	Radiated_V7.6.15.9.5	NA	NA	NA
ANRITSU RF Switches	MP59B	NA	Mar. 6, 2019	Mar. 5, 2020
WOKEN RF cable With 5dB PAD	8D	CABLE-ST3-01	Mar. 6, 2019	Mar. 5, 2020

- Note:
1. The calibration interval of the above test instruments is 12 months and the calibrations are traceable to NML/ROC and NIST/USA.
 2. The test was performed in Open Site No. 3.
 3. The VCCI Site Registration No. is R-269.
 4. Tested Date: Apr. 10, 2019

6.3 Test Arrangement

- The EUT was placed on the top of a rotating table 0.8 meters above the ground at an accredited test facility. The table was rotated 360 degrees to determine the position of the highest radiation.
- The EUT was set 10 meters away from the interference-receiving antenna, which was mounted on the top of a variable-height antenna tower.
- The antenna is a broadband antenna, and its height is varied from one meter to four meters above the ground to determine the maximum value of the field strength. Both horizontal and vertical polarizations of the antenna are set to make the measurement.
- For each suspected emission, the EUT was arranged to its worst case and then the antenna was tuned to heights from 1 meter to 4 meters and the rotatable table was turned from 0 degrees to 360 degrees to find the maximum reading.
- The test-receiver system was set to quasi-peak detect function and specified bandwidth with maximum hold mode when the test frequency is up to 1 GHz.

Note: The resolution bandwidth and video bandwidth of test receiver/spectrum analyzer is 120kHz for quasi-peak detection (QP) at frequency up to 1GHz.

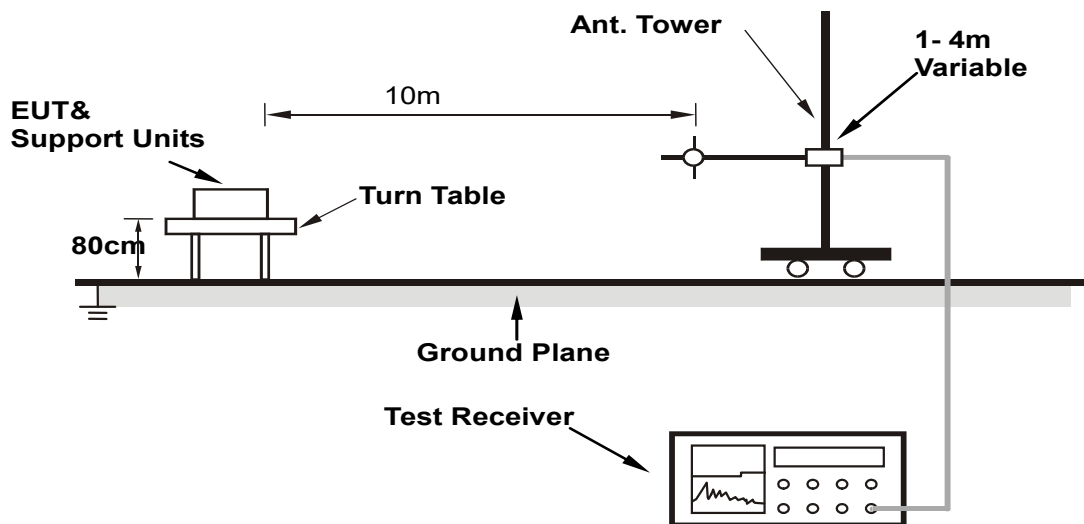

For the actual test configuration, please refer to the related item – Photographs of the Test Configuration.

6.4 Test Results

Frequency Range	30MHz ~ 1GHz	Detector Function & Resolution Bandwidth	Quasi-Peak (QP), 120kHz
Tested by	Vhenson Huang	Environmental Conditions	27°C, 60%RH
Test Mode	Mode 1		

Antenna Polarity & Test Distance : Horizontal at 10 m								
No	Frequency (MHz)	Emission Level (dBuV/m)	Limit (dBuV/m)	Margin (dB)	Antenna Height (m)	Table Angle (Degree)	Raw Value (dBuV)	Correction Factor (dB/m)
1	58.85	26.58 QP	40.00	-13.42	4.00 H	127	47.30	-20.72
2	124.51	35.36 QP	40.00	-4.64	4.00 H	110	49.56	-14.20
3	144.83	35.03 QP	40.00	-4.97	4.00 H	223	49.17	-14.14
4	169.59	37.30 QP	40.00	-2.70	4.00 H	243	52.52	-15.22
5	177.53	37.58 QP	40.00	-2.42	4.00 H	193	53.00	-15.42
6	185.47	37.69 QP	40.00	-2.31	4.00 H	161	53.15	-15.46
7	193.72	35.74 QP	40.00	-4.26	4.00 H	126	51.12	-15.38
8	218.28	35.18 QP	40.00	-4.82	4.00 H	116	49.98	-14.80
9	224.34	37.94 QP	40.00	-2.06	4.00 H	284	52.42	-14.48
10	232.54	42.95 QP	47.00	-4.05	3.86 H	209	56.93	-13.98
11	250.73	43.35 QP	47.00	-3.65	3.71 H	73	55.61	-12.26
12	259.25	44.28 QP	47.00	-2.72	3.25 H	294	55.68	-11.40
13	275.27	43.36 QP	47.00	-3.64	3.18 H	114	55.45	-12.09
14	295.64	44.94 QP	47.00	-2.06	3.08 H	110	56.34	-11.40
15	439.52	37.98 QP	47.00	-9.02	2.13 H	246	45.17	-7.19
16	890.94	40.98 QP	47.00	-6.02	1.00 H	205	40.20	0.78

Remarks:

1. Emission Level(dBuV/m) = Raw Value(dBuV) + Correction Factor(dB/m)
2. Correction Factor(dB/m) = Antenna Factor (dB/m) + Cable Factor (dB) – Pre-Amplifier Factor (dB)
3. The other emission levels were very low against the limit.
4. Margin value = Emission level – Limit value

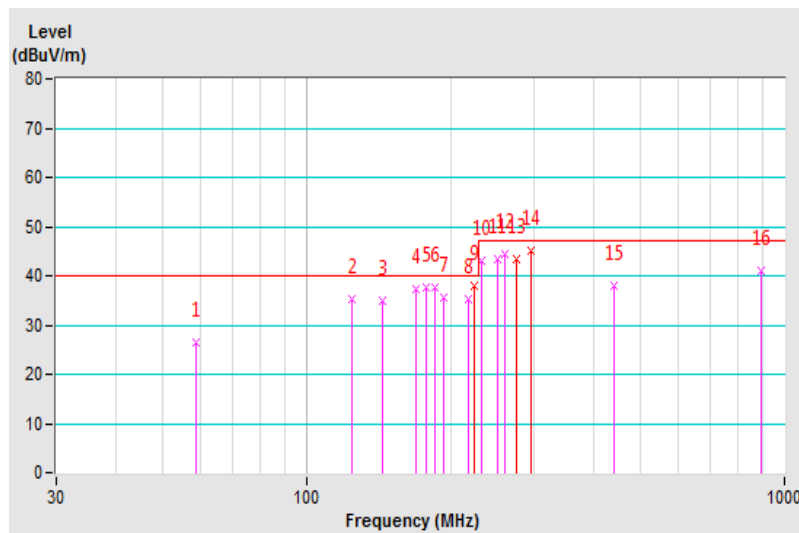

Frequency Range	30MHz ~ 1GHz	Detector Function & Resolution Bandwidth	Quasi-Peak (QP), 120kHz
Tested by	Vhenson Huang	Environmental Conditions	27°C, 60%RH
Test Mode	Mode 1		

Antenna Polarity & Test Distance : Vertical at 10 m								
No	Frequency (MHz)	Emission Level (dBuV/m)	Limit (dBuV/m)	Margin (dB)	Antenna Height (m)	Table Angle (Degree)	Raw Value (dBuV)	Correction Factor (dB/m)
1	34.35	32.53 QP	40.00	-7.47	1.52 V	119	43.66	-11.13
2	68.28	30.32 QP	40.00	-9.68	1.28 V	188	50.36	-20.04
3	124.39	34.96 QP	40.00	-5.04	1.00 V	176	49.16	-14.20
4	168.88	35.86 QP	40.00	-4.14	1.00 V	120	51.05	-15.19
5	193.48	35.36 QP	40.00	-4.64	1.00 V	191	50.73	-15.37
6	225.96	37.55 QP	40.00	-2.45	1.00 V	26	51.94	-14.39
7	232.34	42.45 QP	47.00	-4.55	1.00 V	50	56.44	-13.99
8	258.90	43.91 QP	47.00	-3.09	1.00 V	49	55.34	-11.43
9	266.90	43.35 QP	47.00	-3.65	1.00 V	126	55.39	-12.04
10	299.63	43.97 QP	47.00	-3.03	1.00 V	249	55.32	-11.35
11	333.15	40.82 QP	47.00	-6.18	1.00 V	344	51.46	-10.64
12	446.50	38.02 QP	47.00	-8.98	1.54 V	16	45.04	-7.02
13	742.51	36.31 QP	47.00	-10.69	2.67 V	210	37.10	-0.79
14	890.98	42.24 QP	47.00	-4.76	2.14 V	10	41.46	0.78

Remarks:

1. Emission Level(dBuV/m) = Raw Value(dBuV) + Correction Factor(dB/m)
2. Correction Factor(dB/m) = Antenna Factor (dB/m) + Cable Factor (dB) – Pre-Amplifier Factor (dB)
3. The other emission levels were very low against the limit.
4. Margin value = Emission level – Limit value

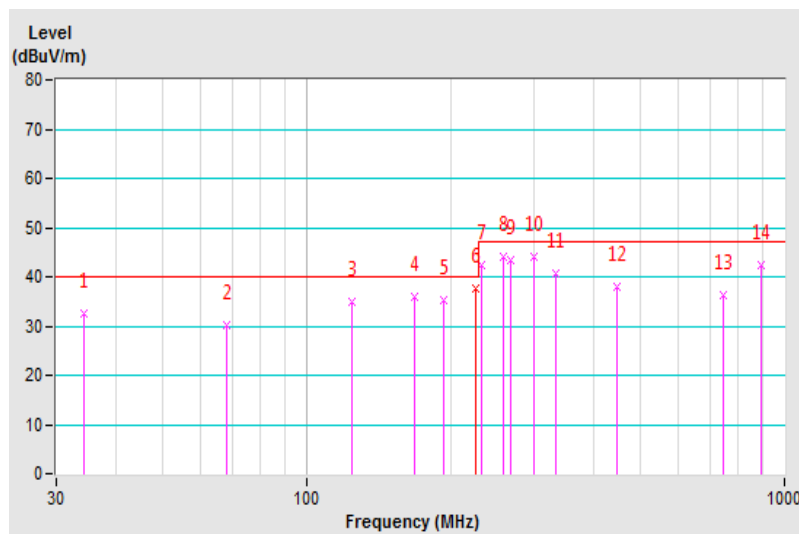

7 Radiated Emissions above 1 GHz

7.1 Limits

Emissions radiated outside of the specified bands, shall be according to the general radiated limits as following:

Radiated Emissions Limits at 10 meters (dB μ V/m)				
Frequencies (MHz)	FCC 15B / ICES-003, Class A	FCC 15B / ICES-003, Class B	CISPR 22, Class A	CISPR 22, Class B
1000-3000	Avg: 49.5	Avg: 43.5	Not defined	Not defined
Above 3000	Peak: 69.5	Peak: 63.5	Not defined	Not defined

Radiated Emissions Limits at 3 meters (dB μ V/m)				
Frequencies (MHz)	FCC 15B / ICES-003, Class A	FCC 15B / ICES-003, Class B	CISPR 22, Class A	CISPR 22, Class B
1000-3000	Avg: 60	Avg: 54	Avg: 56 Peak: 76	Avg: 50 Peak: 70
Above 3000	Peak: 80	Peak: 74	Avg: 60 Peak: 80	Avg: 54 Peak: 74

- Notes: 1. The lower limit shall apply at the transition frequencies.
 2. Emission level (dB μ V/m) = 20 log Emission level (uV/m).
 3. As shown in 15.35(b), for frequencies above 1000MHz, the field strength limits are based on average detector, however, the peak field strength of any emission shall not exceed the maximum permitted average limits, specified above by more than 20dB under any condition of modulation.

Frequency Range (For unintentional radiators)

Highest frequency generated or used in the device or on which the device operates or tunes (MHz)	Upper frequency of measurement range (MHz)
Below 1.705	30
1.705-108	1000
108-500	2000
500-1000	5000
Above 1000	5th harmonic of the highest frequency or 40GHz, whichever is lower

7.2 Test Instruments

Description & Manufacturer	Model No.	Serial No.	Cal. Date	Cal. Due
Agilent Spectrum	E4446A	MY51100009	Jun. 4, 2018	Jun. 3, 2019
Agilent Test Receiver	N9038A	MY50010135	Jun. 23, 2018	Jun. 22, 2019
Agilent Preamplifier	8449B	3008A01924	Feb. 21, 2019	Feb. 20, 2020
MITEQ Preamplifier	AMF-6F-260400-33-8P	892164	Feb. 21, 2019	Feb. 20, 2020
EMCI Preamplifier	EMC184045B	980235	Feb. 21, 2019	Feb. 20, 2020
ETS Preamplifier	3117-PA	00215857	Nov. 25, 2018	Nov. 24, 2019
Schwarzbeck Horn Antenna	BBHA-9170	212	Nov. 25, 2018	Nov. 24, 2019
EMCO Horn Antenna	3115	9312-4192	Nov. 25, 2018	Nov. 24, 2019
Max Full. Turn Table & Tower	MF7802	MF780208103	NA	NA
Software	Radiated_V8.7.08	NA	NA	NA
SUHNER RF cable With 4dB PAD	SF106-18	Cable-CH7-01	Aug. 13, 2018	Aug. 12, 2019
SUHNER RF cable With 3/4dB PAD	SF102	Cable-CH7-3.6m	Aug. 13, 2018	Aug. 12, 2019
MICRO-TRONICS Notch filter	BRC50703-01	010	May 31, 2018	May 30, 2019
MICRO-TRONICS Band Pass Filter	BRM17690	005	May 31, 2018	May 30, 2019

- Note:
1. The calibration interval of the above test instruments is 12 months and the calibrations are traceable to NML/ROC and NIST/USA.
 2. The test was performed in Chamber No. 7.
 3. The VCCI Site Registration No. G-10039
 4. Tested Date: Apr. 11, 2019

7.3 Test Arrangement

- The EUT was placed on the top of a rotating table 0.8 meters above the ground at an accredited chamber room. The table was rotated 360 degrees to determine the position of the highest radiation.
- The EUT was set 3 meters away from the interference-receiving antenna, which was mounted on the top of a variable-height antenna tower.
- The height of antenna can be varied from one meter to four meters, the height of adjustment depends on the EUT height and the antenna 3dB beamwidth both, to detect the maximum value of the field strength. Both horizontal and vertical polarizations of the antenna are set to make the measurement.
- For each suspected emission, the EUT was arranged to its worst case and then the antenna was tuned to heights and the rotatable table was turned from 0 degrees to 360 degrees to find the maximum reading.
- The spectrum analyzer system was set to peak and average detect function and specified bandwidth with maximum hold mode when the test frequency is above 1 GHz.

Note: The resolution bandwidth of test receiver/spectrum analyzer is 1MHz and video bandwidth is 3MHz for Peak detection (PK) at frequency above 1GHz. The resolution bandwidth of test receiver/spectrum analyzer is 1 MHz for Average detection (AV) at frequency above 1GHz.

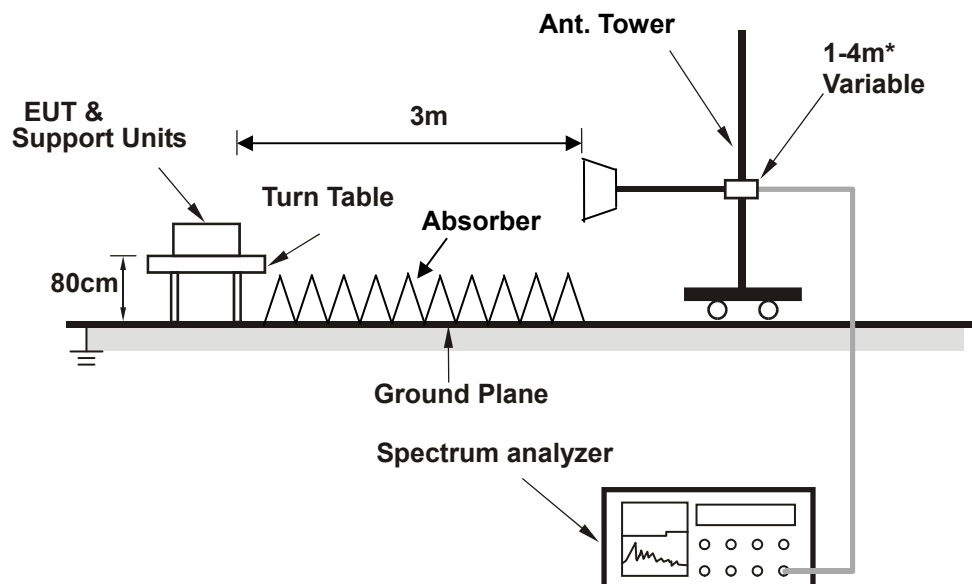

* :depends on the EUT height and the antenna 3dB beamwidth both.

For the actual test configuration, please refer to the related item – Photographs of the Test Configuration.

7.4 Test Results

Frequency Range	1GHz ~ 8GHz	Detector Function & Resolution Bandwidth	Peak (PK) / Average (AV), 1MHz
Tested by	Ken Lee	Environmental Conditions	23°C, 71%RH
Test Mode	Mode 1		

Antenna Polarity & Test Distance : Horizontal at 3 m								
No	Frequency (MHz)	Emission Level (dBuV/m)	Limit (dBuV/m)	Margin (dB)	Antenna Height (m)	Table Angle (Degree)	Raw Value (dBuV)	Correction Factor (dB/m)
1	1186.68	52.36 PK	80.00	-27.64	1.00 H	242	57.89	-5.53
2	1186.68	38.44 AV	60.00	-21.56	1.00 H	242	43.97	-5.53
3	1499.69	52.72 PK	80.00	-27.28	1.04 H	343	58.56	-5.84
4	1499.69	40.26 AV	60.00	-19.74	1.04 H	343	46.10	-5.84
5	1995.79	53.14 PK	80.00	-26.86	1.01 H	355	56.81	-3.67
6	1995.79	37.03 AV	60.00	-22.97	1.01 H	355	40.70	-3.67
7	3500.02	53.39 PK	80.00	-26.61	1.17 H	149	52.15	1.24
8	3500.02	36.96 AV	60.00	-23.04	1.17 H	149	35.72	1.24

Remarks:

1. Emission Level(dBuV/m) = Raw Value(dBuV) + Correction Factor(dB/m)
2. Correction Factor(dB/m) = Antenna Factor (dB/m) + Cable Factor (dB) – Pre-Amplifier Factor (dB)
3. The other emission levels were very low against the limit.
4. Margin value = Emission level – Limit value

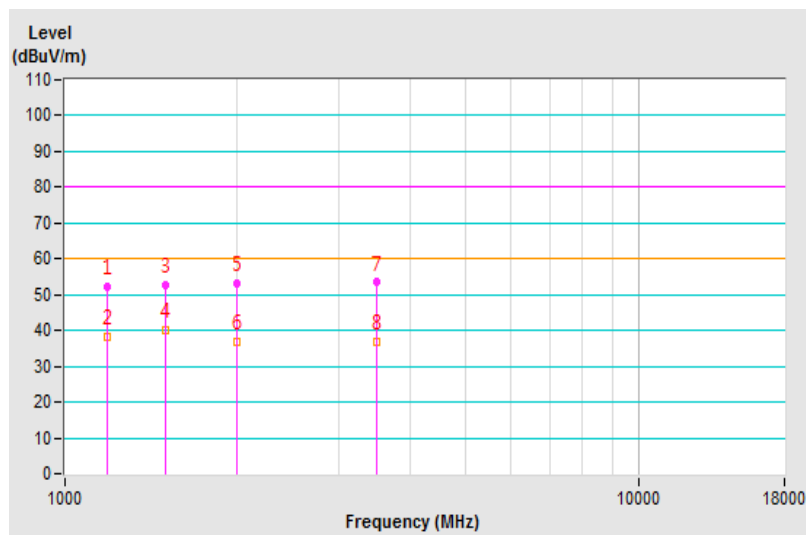

Frequency Range	1GHz ~ 8GHz	Detector Function & Resolution Bandwidth	Peak (PK) / Average (AV), 1MHz
Tested by	Ken Lee	Environmental Conditions	23°C, 71%RH
Test Mode	Mode 1		

Antenna Polarity & Test Distance : Vertical at 3 m								
No	Frequency (MHz)	Emission Level (dBuV/m)	Limit (dBuV/m)	Margin (dB)	Antenna Height (m)	Table Angle (Degree)	Raw Value (dBuV)	Correction Factor (dB/m)
1	1186.76	53.47 PK	80.00	-26.53	1.00 V	194	59.00	-5.53
2	1186.76	40.00 AV	60.00	-20.00	1.00 V	194	45.53	-5.53
3	1996.65	55.12 PK	80.00	-24.88	1.00 V	188	58.79	-3.67
4	1996.65	41.09 AV	60.00	-18.91	1.00 V	188	44.76	-3.67
5	2957.76	57.90 PK	80.00	-22.10	1.13 V	145	58.55	-0.65
6	2957.76	35.97 AV	60.00	-24.03	1.13 V	145	36.62	-0.65

Remarks:

1. Emission Level(dBuV/m) = Raw Value(dBuV) + Correction Factor(dB/m)
2. Correction Factor(dB/m) = Antenna Factor (dB/m) + Cable Factor (dB) – Pre-Amplifier Factor (dB)
3. The other emission levels were very low against the limit.
4. Margin value = Emission level – Limit value

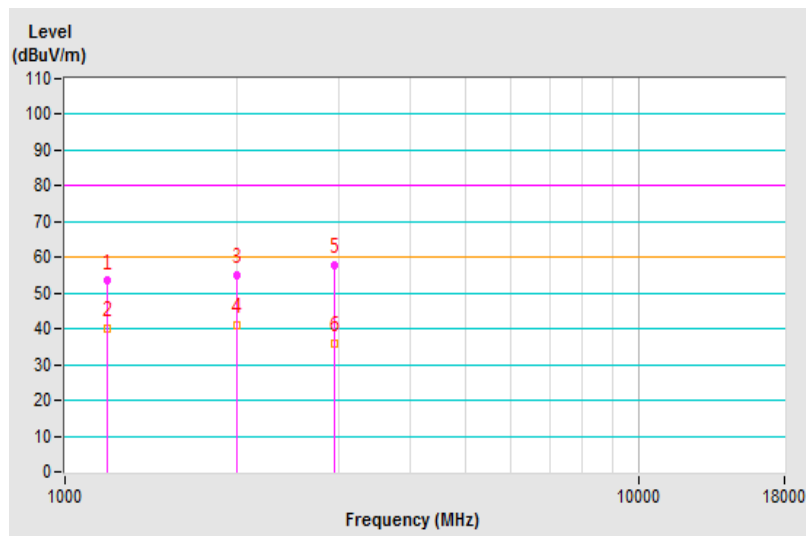

8 Pictures of Test Arrangements

8.1 Conducted Emissions at Mains Ports

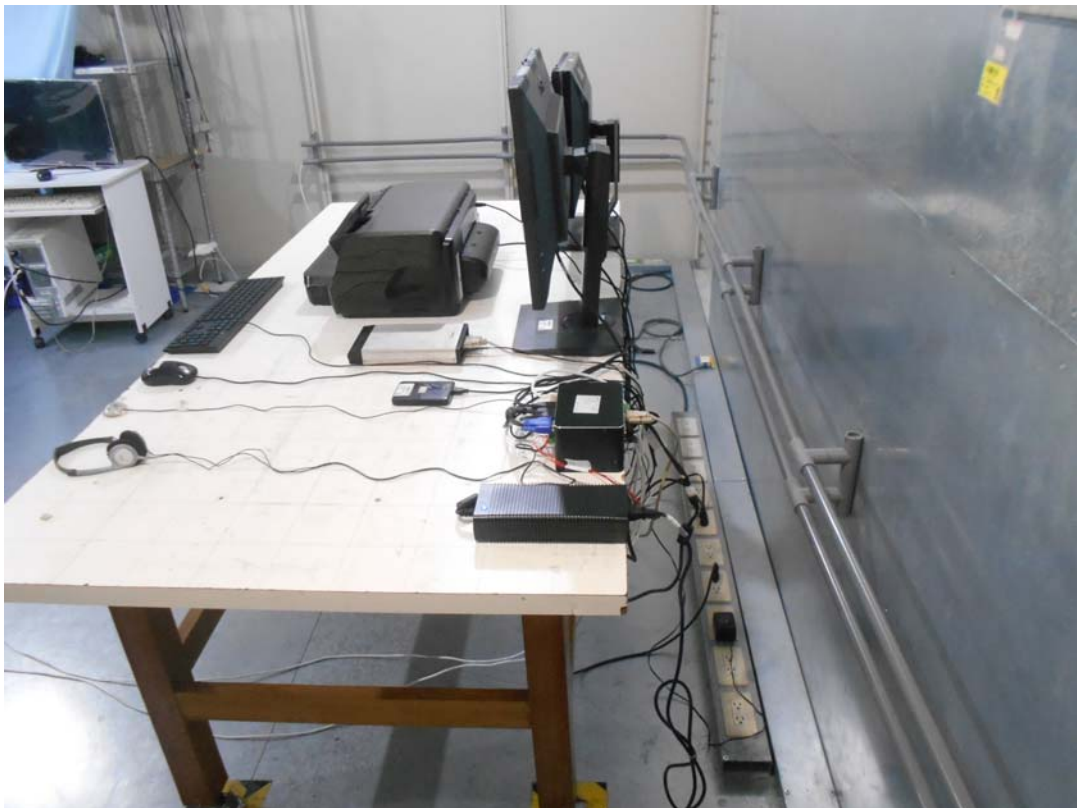

8.2 Radiated Emissions up to 1 GHz

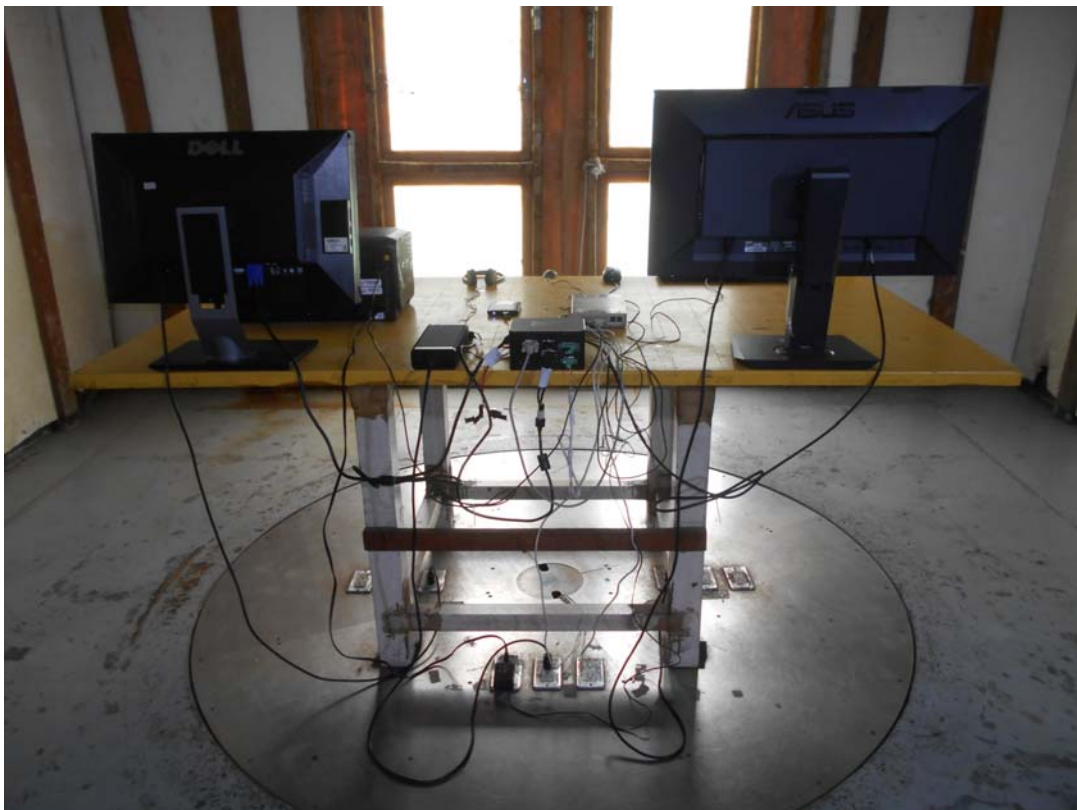

8.3 Radiated Emissions above 1 GHz

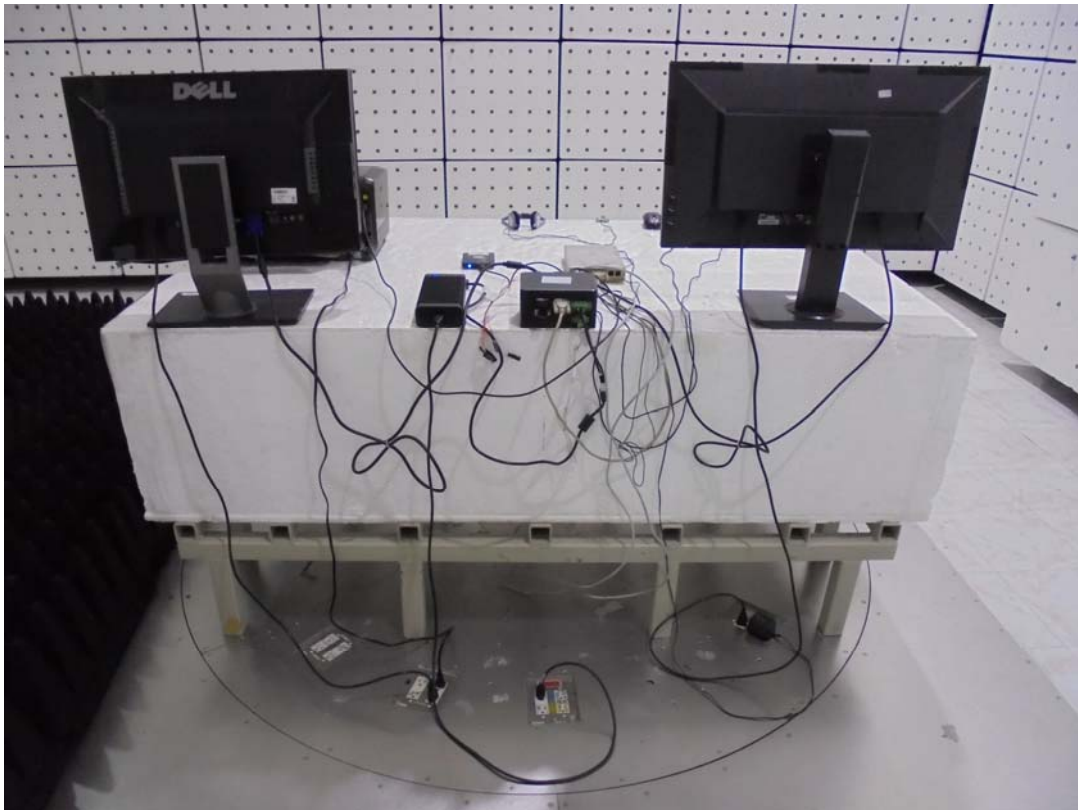

Appendix – Information of the Testing Laboratories

We, Bureau Veritas Consumer Products Services (H.K.) Ltd., Taoyuan Branch, were founded in 1988 to provide our best service in EMC, Radio, Telecom and Safety consultation. Our laboratories are FCC recognized accredited test firms and accredited according to ISO/IEC 17025.

If you have any comments, please feel free to contact us at the following:

Lin Kou EMC/RF Lab

Tel: 886-2-26052180

Fax: 886-2-26051924

Hsin Chu EMC/RF/Telecom Lab

Tel: 886-3-6668565

Fax: 886-3-6668323

Hwa Ya EMC/RF/Safety Lab

Tel: 886-3-3183232

Fax: 886-3-3270892

Email: service.adt@tw.bureauveritas.com

Web Site: www.bureauveritas-adt.com

The address and road map of all our labs can be found in our web site also.

--- END ---